

OPX1000 Mounting Guide

19" Rack Installation

Document V1.5

Before You Start



1.1 Safety Warning

1. An OPX1000 system may weigh up to 40 kg, depending on the FEMs & other components installed. Before lifting it, consult your local safety rules.
2. It is highly recommended that two people perform the installation.
3. The system shall always be installed and operated while fully inserted and retained to the rack. Sliding the system out is allowed only for the empty chassis and only for mounting or dismounting from the rack.
4. The mounting brackets kit is meant to be installed in a threadless rack. Please install it on a shelf in threaded racks.

1.2 Rack Mounting Kit Components

Make sure that you have the following parts:

1. 1x Left sliding rail assembly (MP0285).
2. 1x Right sliding rail assembly (MP0286).
3. 2x Rear mounting plate bracket (MP0179).
4. 2x Front mounting plate bracket (MP0182).
5. 12x M6 cage nuts (NT0010).
6. 4x M6 flat head screws (SC0044).
7. 8x M6 pan head screws (SC0055).

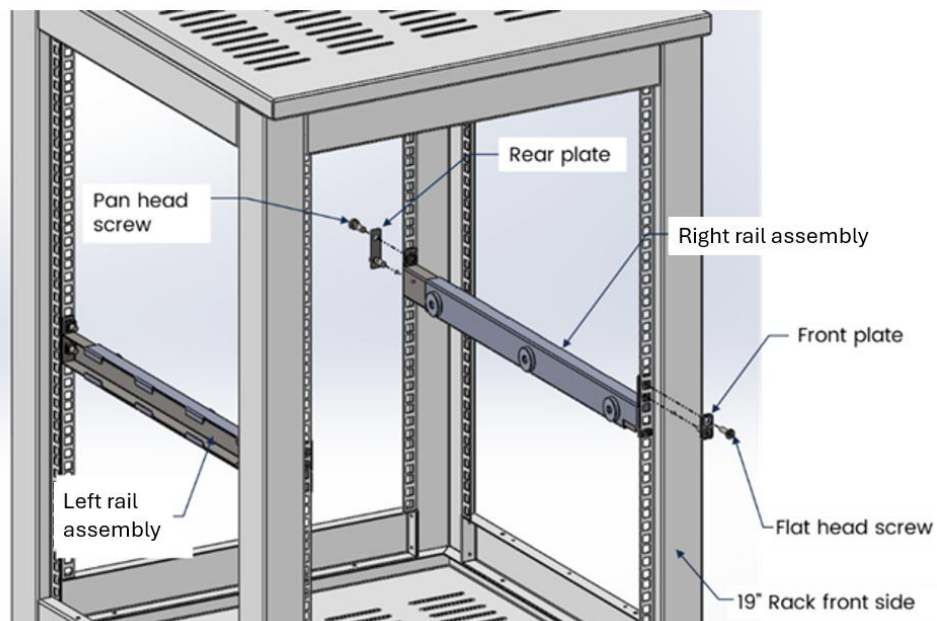

Figure 1 – Rack Mounting Kit Main Components

1.3 Required Tools

1. Phillips type 3 Screwdriver.
2. Torx T10 Screwdriver.
3. Torx T15 Screwdriver.

1.4 Chassis Modifications

- If the OPX1000 chassis is installed using the rails, the rubber feet can be removed using a T10 screwdriver.

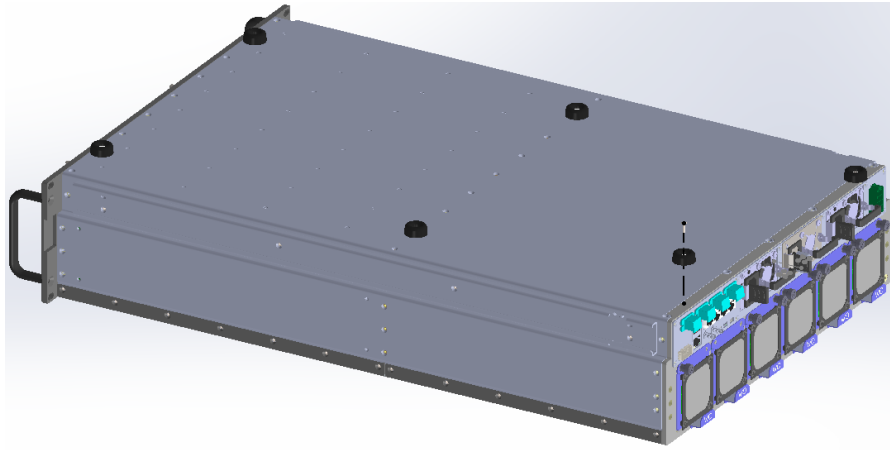

Figure 2 - Removal of the rubber feet

- If the OPX1000 chassis is not to be installed using the rails, the side rails can be removed using a T10 screwdriver.

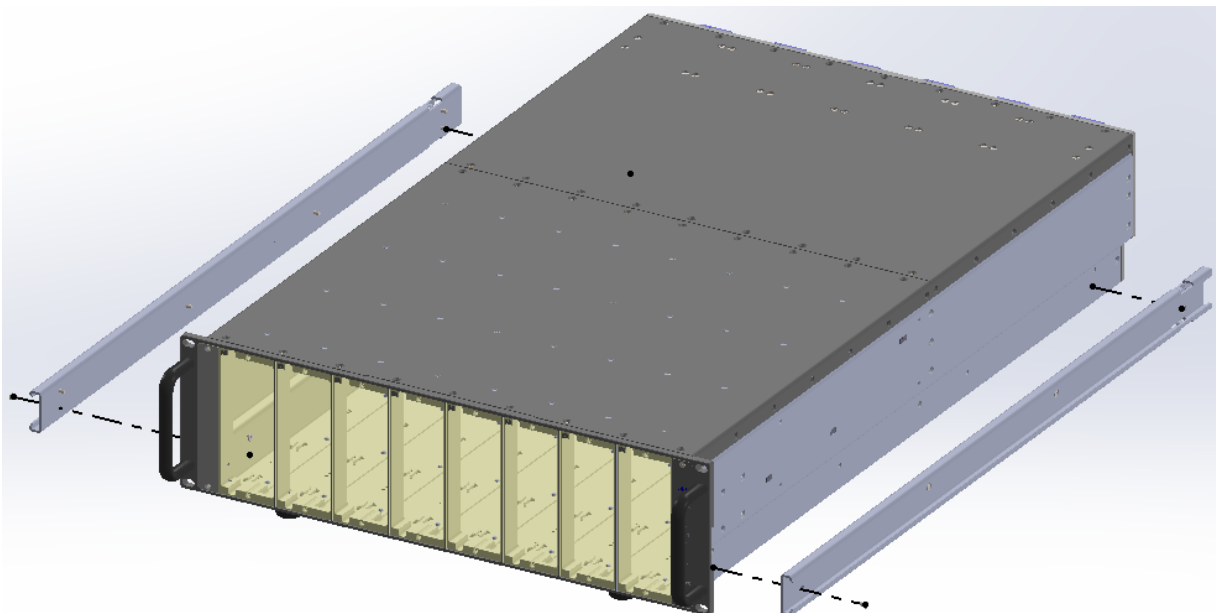

Figure 3 - Removal of the side rails

Rack Installation Process



Note:

OPX1000 chassis shipped before May 2024 use an older rail revision that is not mechanically compatible with newer chassis. If you are rearranging the rack and have older chassis, please keep each rail pair with its original chassis. Do not leave rails installed in the rack and mount a different chassis generation on them.

1. The distance between the rack mounting beam should be 600-900 mm.

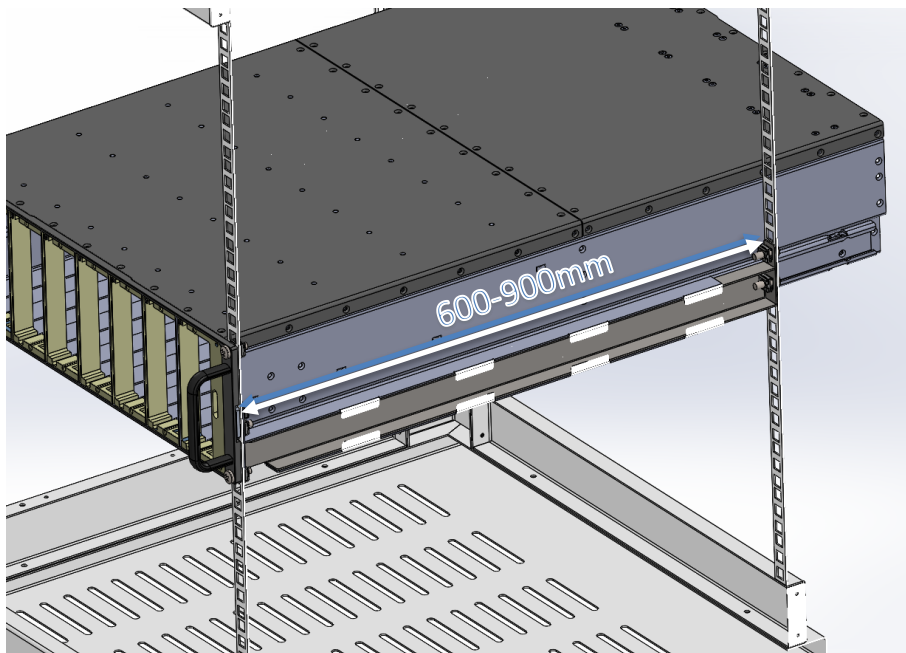
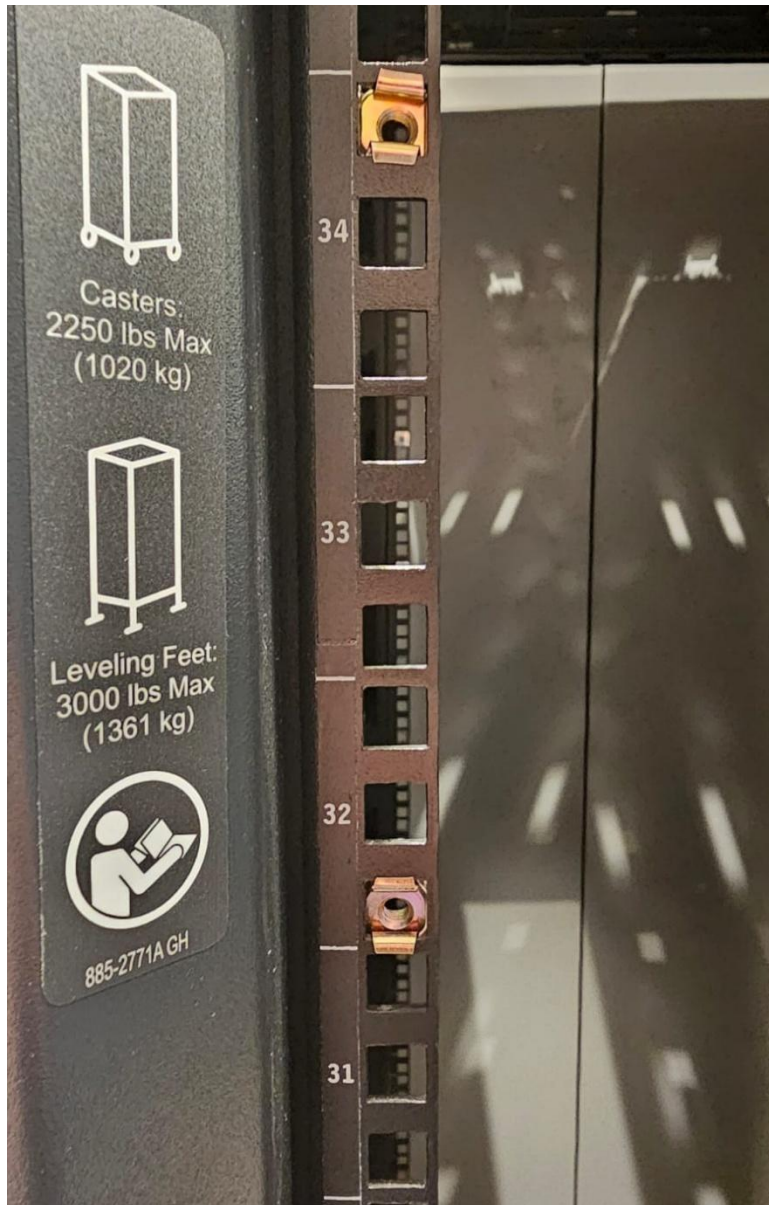

Figure 4 - Distance between the rack beams

2. **Cage nuts installation on the rack:** On the system’s front side, install 4x cage nuts (NT0010): 2 on the left beam and 2 on the right beam. 1x cage nut should be installed on the very bottom hole of the 1st U of the rack space planned for installation, while the other one should be installed on the very top hole of the 3rd U. See an example of the cage nuts inserted for a OPX1000 system installation into 32U – 34U rack space:



Picture 1 – Cage nuts installed in a rack

- Cage nuts installation on the mounting rails:** Install 2x cage nuts (NT0010) on each side of both left and right rail assemblies (MP0285 and MP0286) for a total of 8x cage nuts. The cage nuts should be inserted from the inner side of the assemblies – see the pictures below.



Picture 2 - Back side of the rail assembly with cage nuts installed



Picture 3 - Front side of the mounting assembly with cage nuts installed



4. **Position right rail assembly:** Place the right rail assembly (MP0286) in the appropriate location in the rack. The rail assembly should be attached to the inner side of the rack beams.



Picture 4 – Front side view of the rack with the rail assembly location indicated

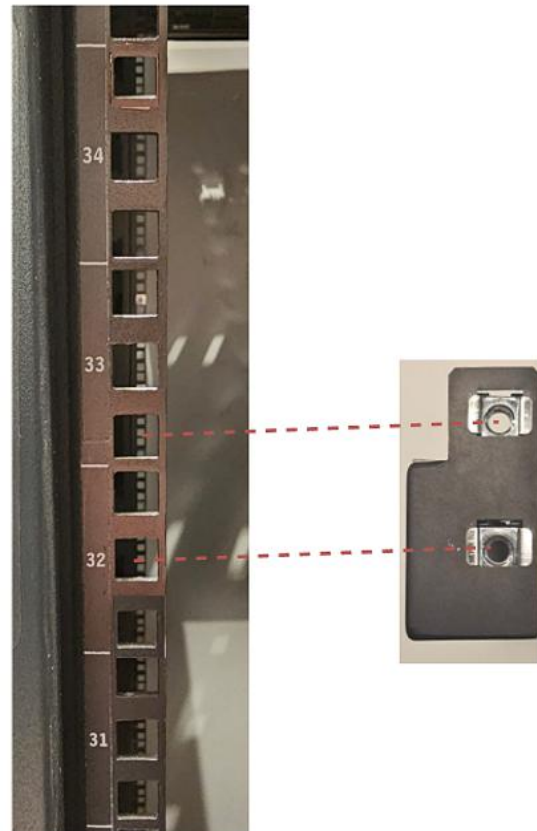

Picture 5 – Back side view of the rack with the rail assembly location indicated

5. **Secure the rail assembly front side:** Use 2x M6 flat head screws (SC0044) to secure the rail assembly (MP0286) to the rack beam with the front mounting plate bracket (MP0182).

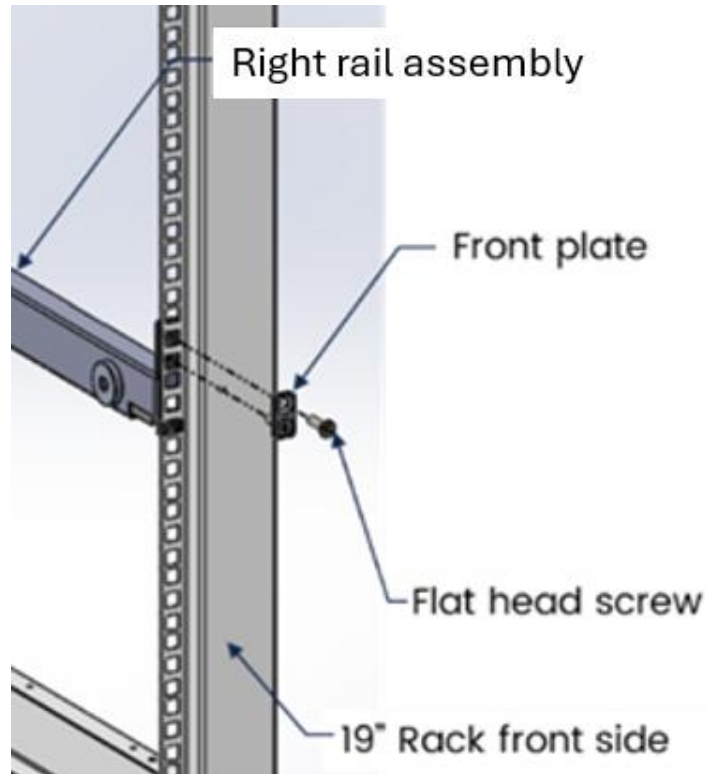

Figure 5 – Rail assembly and front plate installation

6. **Secure the rail assembly rear side:** Use 2x M6 pan head screws (SC0055) to secure the rail assembly (MP0286) to the rack beam with the rear mounting plate bracket (MP0179). Slide the rail assembly back as much as needed.

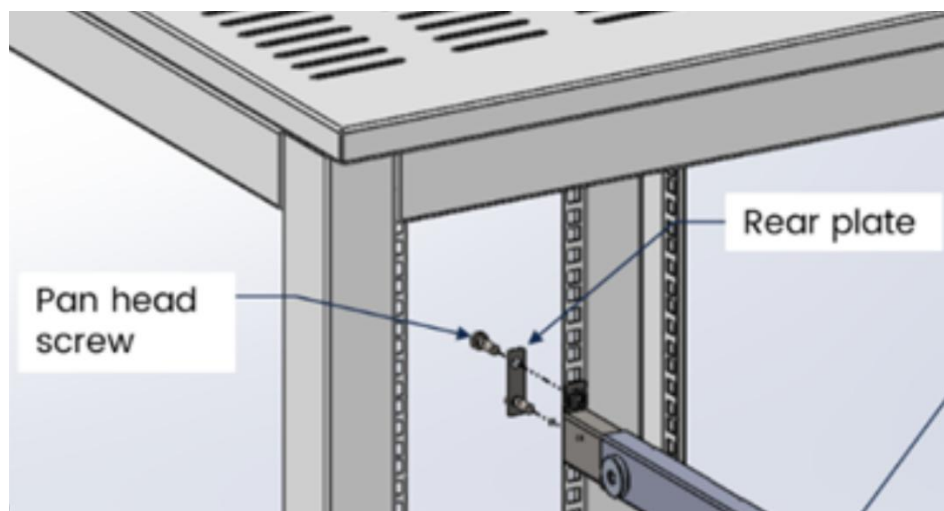

Figure 6 – Rail assembly and back plate installation

7. **Tighten the right rail assembly:** Secure the right rail assembly by tightening the screws from both sides. Gently push it outwards as you tighten to make all parts flat with the rack beam.
8. **Repeat for left rail assembly:** Repeat steps 4-7 to mount the left rail assembly (MP0285).
9. **Mount OPX1000:** Once the rail assemblies are firmly installed and secured, gently lift and slide the OPX1000 onto them. Be aware of the heavy weight of the OPX1000, especially in the rear end. Note that some force needs to be applied while sliding the OPX1000 into the rail assemblies. Two people are required for this step.

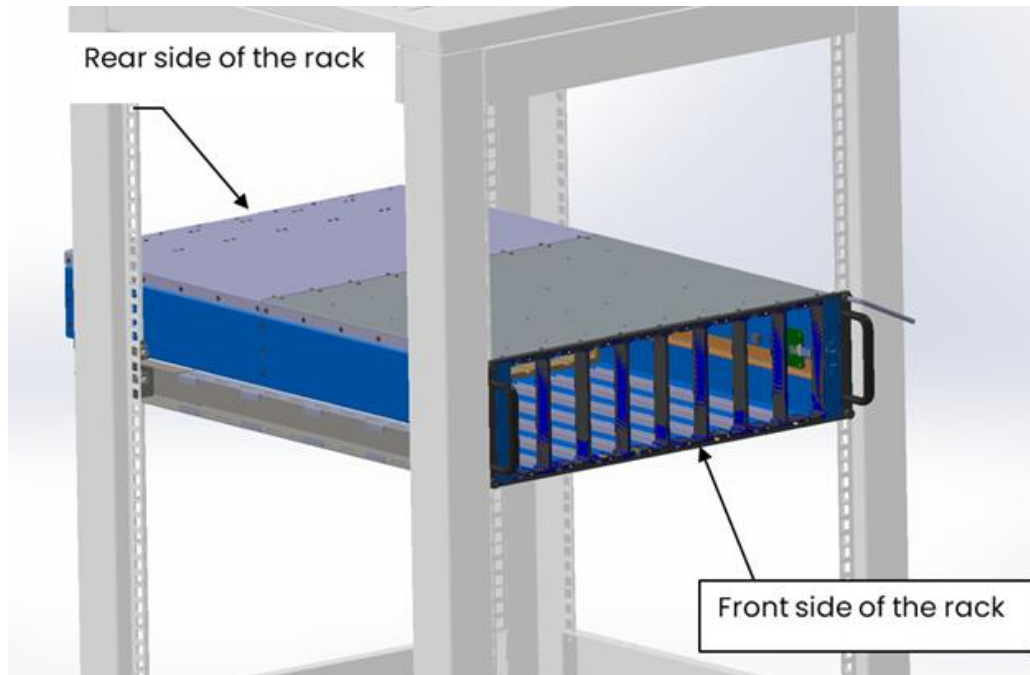

Figure 7: Mounted OPX1000 chassis

10. **Secure OPX1000:** Secure the OPX1000 using four M6 pan screws (SC055) to the cage nuts installed in the rack at step 1.

OPX1000 System Grounding

The OPX1000 chassis must have an additional independent protective grounding connection.

We recommend using the ground cable supplied with the system (CB0126) to ground the system.

- Drawing of QM provided ground cable:

ITEM NO.	PART NUMBER	DESCRIPTION	NOTE	QTY.
1	GROUND CABLE	3206-45	WIECI 6AWG 600V WIRE, YELLOW/GREEN	1
2	M6 CABLE LUG	RNBS14-6	RING TERMINAL K.S	1
3	M4 CABLE LUG	RNB14-4	RNB14-4	1
4	HEAT SHRINK	PFL100-3/8"	PLATRONICS BLACK SHRINK 3/8"	2

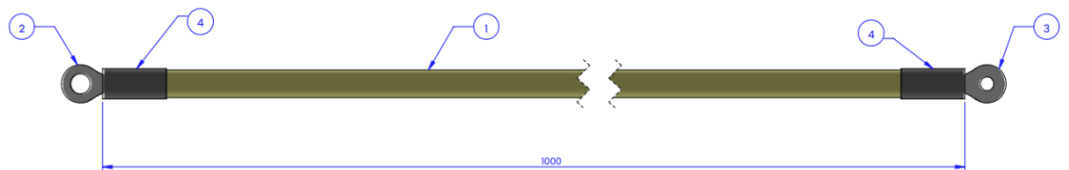

If an alternative ground cable is to be used, it must comply with the following spec:

- Wire minimum cross-sectional area shall be 1.5mm² or greater.
- The cable side to be connected to the system shall have M4 screw lug.

Installation steps:

1. Locate the ground post location at the top left corner at the back side of the system.

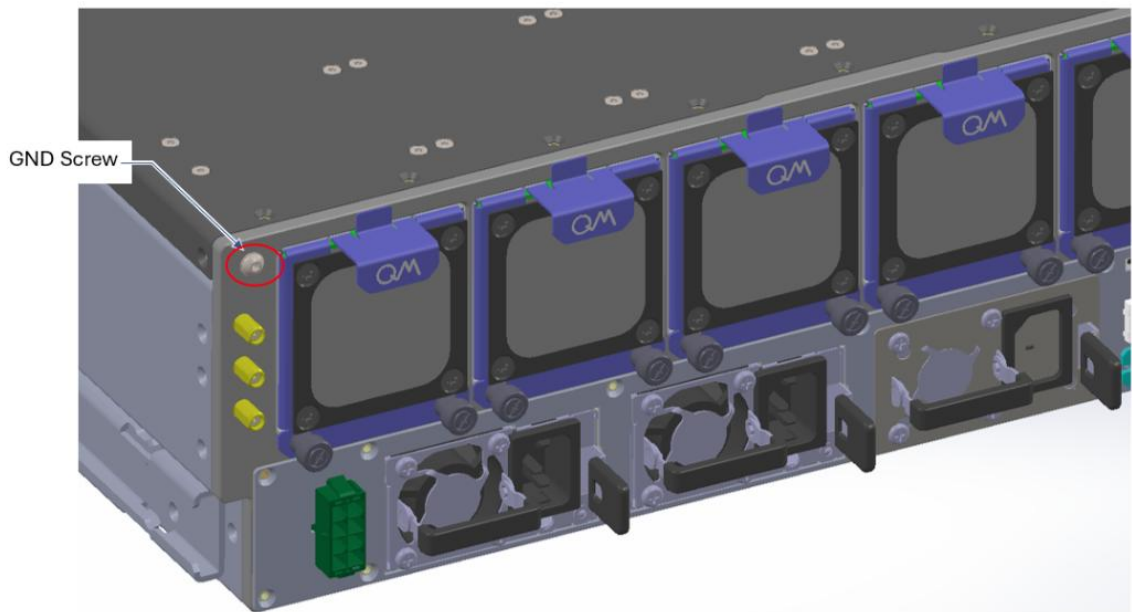

2. Use a T15 screwdriver (M4 screw) to attach the ground cable to the chassis. Ensure the cable lag is tightly attached to the system surface without any obstacles.
3. Connect the other part of the cable to the main ground post of the building/room/rack.
 - a. If the supplied ground cable is used (CB0126), note that it has an M6 lug at the other side.

Contact Us

For installation issues and assistance, please contact Quantum Machines support. See the documentation website at <http://docs.quantum-machines.co/> for up-to-date support information.